

tend MAIN SWITCH

เมนสวิตช์

FEATURE

- These series of switches has 5 types of capacity ranging from 16A to 66A.
- Installation includes fixed way (fixed on the operating panel) and detached way (contact fixed in the control box whereas upper base and handles fixed on the top cover of the control box)
- Detachable type can be installed on TBR-N (standard aluminium rail-wide rail)
- There are two types of switching handles : standard and round. Standard is colored in red, yellow or black, silver while round ones in red, yellow or black, gray.

MODEL DESIGNATION

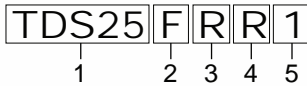

Designation	Signal	Description
1. Capacity	TDS16	16A
	TDS25	25A
	TDS33	33A
	TDS40	40A
	TDS66	66A
2. Installation way	F	Fixed way
	B	Detached way
	E	Control stations
3. Handle	S	Standard handle
	R	Rotundity handle
4. Color	B	Black / Silver / Gray
	R	Red / Yellow
5. Transmission rod length (only detached way)	None	100 mm
	1	150 mm
	2	250 mm
	3	300 mm

Type	Voltage	TDS16	TDS25	TDS33	TDS40	TDS66
		AC-3 (kw)				
AC-3 (kw)	220V - 240V	2.2	4	5.5	7.5	11.0
	380V - 440V	3.7	5.5	7.5	11.0	18.5
	660V - 690V	3.7	5.5	7.5	15.0	22.5
AC-23A (kw)						
AC-23A (kw)	220V - 240V	3.0	5.5	5.5	7.5	11.0
	380V - 440V	5.5	7.5	11.5	15.0	22.0
	660V - 690V	3.7	7.5	11.5	18.5	30.0
AC-21						
		16A	25A	33A	40A	66A
Type	Voltage	TDS16	TDS25	TDS33	TDS40	TDS66
		AC-3 (hp)				
AC-3 (hp)	110V - 120V	1	1.5	2	3	5
	220V - 440V	2	3	5	7.5	10
	380V - 440V	3	5	10	15	20
	660V - 690V	3	5	10	15	20

3 phase . 3 poles

PLATE DIMENSIONS

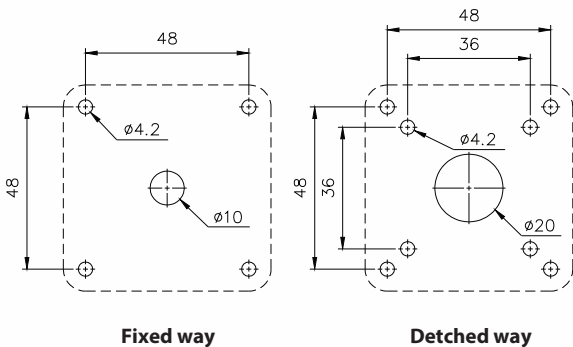

WIRING DIAGRAM

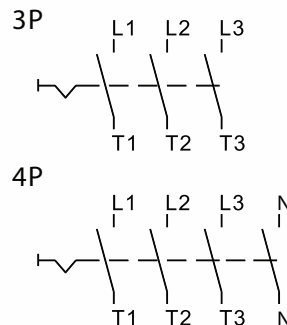

TBR-N (Dimensions)

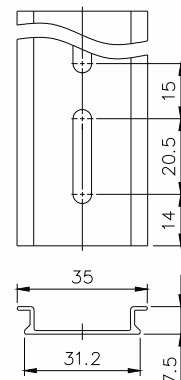

tend MAIN SWITCH

เมนสวิตช์

DIMENSIONS

Fixed Way Standard Handle

- 1 TDS16/25/33-FSB
หน้าปัดสีขาว ลูกบิดสีดำ
- 2 TDS16/25/33-FSR
หน้าปัดสีเหลือง ลูกบิดสีแดง

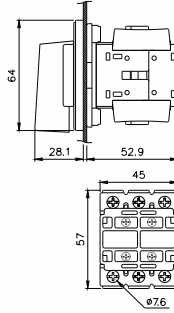

Type	Price
TDS16(16A)-FSB	1,110.-
TDS16(16A)-FSR	1,110.-
TDS25(25A)-FSB	1,210.-
TDS25(25A)-FSR	1,210.-
TDS33(33A)-FSB	1,430.-
TDS33(33A)-FSR	1,430.-

Fixed Way Rotundity Handle

- 1 TDS16/25/33-FRB
หน้าปัดสีขาว ลูกบิดสีดำ
- 2 TDS16/25/33-FRR
หน้าปัดสีเหลือง ลูกบิดสีแดง

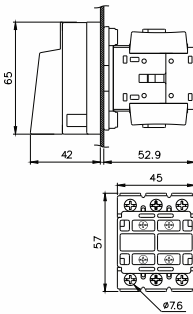
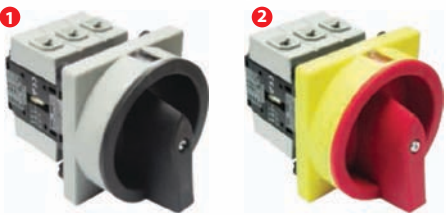

Type	Price
TDS16(16A)-FRB	1,110.-
TDS16(16A)-FRR	1,110.-
TDS25(25A)-FRB	1,210.-
TDS25(25A)-FRR	1,210.-
TDS33(33A)-FRB	1,430.-
TDS33(33A)-FRR	1,430.-

Detched Way Standard Handle

- 1 TDS16/25/33-BSB
หน้าปัดสีขาว ลูกบิดสีดำ
- 2 TDS16/25/33-BSR
หน้าปัดสีเหลือง ลูกบิดสีแดง

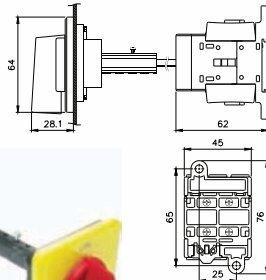

Type	Price	Type	Price
TDS16(16A)-BSB	1,210.-	TDS16(16A)-BSR	1,210.-
TDS16(16A)-BSB1	1,210.-	TDS16(16A)-BSR1	1,210.-
TDS16(16A)-BSB2	1,300.-	TDS16(16A)-BSR2	1,300.-
TDS16(16A)-BSB3	1,300.-	TDS16(16A)-BSR3	1,300.-
TDS25(25A)-BSB	1,300.-	TDS25(25A)-BSR	1,300.-
TDS25(25A)-BSB1	1,300.-	TDS25(25A)-BSR1	1,300.-
TDS25(25A)-BSB2	1,430.-	TDS25(25A)-BSR2	1,430.-
TDS25(25A)-BSB3	1,430.-	TDS25(25A)-BSR3	1,430.-
TDS33(33A)-BSB	1,540.-	TDS33(33A)-BSR	1,540.-
TDS33(33A)-BSB1	1,540.-	TDS33(33A)-BSR1	1,540.-
TDS33(33A)-BSB2	1,630.-	TDS33(33A)-BSR2	1,630.-
TDS33(33A)-BSB3	1,630.-	TDS33(33A)-BSR3	1,630.-

Detched Way Rotundity Handle

- 1 TDS16/25/33-BRB
หน้าปัดสีขาว ลูกบิดสีดำ
- 2 TDS16/25/33-BRR
หน้าปัดสีเหลือง ลูกบิดสีแดง

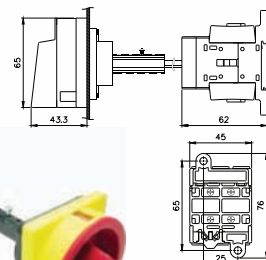

Type	Price	Type	Price
TDS16(16A)-BRB	1,210.-	TDS16(16A)-BRR	1,210.-
TDS16(16A)-BRB1	1,210.-	TDS16(16A)-BRR1	1,210.-
TDS16(16A)-BRB2	1,300.-	TDS16(16A)-BRR2	1,300.-
TDS16(16A)-BRB3	1,300.-	TDS16(16A)-BRR3	1,300.-
TDS25(25A)-BRB	1,300.-	TDS25(25A)-BRR	1,300.-
TDS25(25A)-BRB1	1,300.-	TDS25(25A)-BRR1	1,300.-
TDS25(25A)-BRB2	1,430.-	TDS25(25A)-BRR2	1,430.-
TDS25(25A)-BRB3	1,430.-	TDS25(25A)-BRR3	1,430.-
TDS33(33A)-BRB	1,540.-	TDS33(33A)-BRR	1,540.-
TDS33(33A)-BRB1	1,540.-	TDS33(33A)-BRR1	1,540.-
TDS33(33A)-BRB2	1,630.-	TDS33(33A)-BRR2	1,630.-
TDS33(33A)-BRB3	1,630.-	TDS33(33A)-BRR3	1,630.-

หมายเหตุ : ราคานี้พร้อมก้านมาตรฐาน 100 มม. มีก้านความยาวอีก 3 ขนาด สามารถเปลี่ยนได้ตามความต้องการราคาก้านยาว 150 มม. ก้านยาว 250 มม. ก้านยาว 300 มม.

tend MAIN SWITCH

เมนสวิตช์

DIMENSIONS

Fixed Way Standard Handle

- 1 TDS40/66/80-FSB
หน้าปัดสีขาว ลูกบิดสีดำ
- 2 TDS40/60/80-FSR
หน้าปัดสีเหลือง ลูกบิดสีแดง

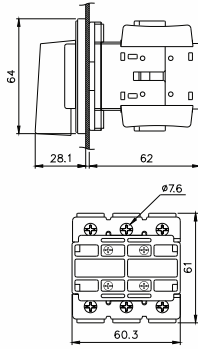

Type	Price
TDS40(40A)-FSB	1,720.-
TDS40(40A)-FSR	1,720.-
TDS66(66A)-FSB	2,160.-
TDS66(66A)-FSR	2,160.-
TDS80(80A)-FSB	2,850.-
TDS80(80A)-FSR	2,850.-

Fixed Way Rotundity Handle

- 1 TDS40/66/80-FRB
หน้าปัดสีขาว ลูกบิดสีดำ
- 2 TDS40/66/80-FRR
หน้าปัดสีเหลือง ลูกบิดสีแดง

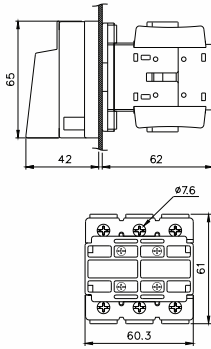

Type	Price
TDS40(40A)-FRB	1,720.-
TDS40(40A)-FRR	1,720.-
TDS66(66A)-FRB	2,160.-
TDS66(66A)-FRR	2,160.-
TDS80(80A)-FRB	2,850.-
TDS80(80A)-FRR	2,850.-

Detched Way Rotundity Handle

- 1 TDS40/66/80-BSB
หน้าปัดสีขาว ลูกบิดสีดำ
- 2 TDS40/66/80-BSR
หน้าปัดสีเหลือง ลูกบิดสีแดง

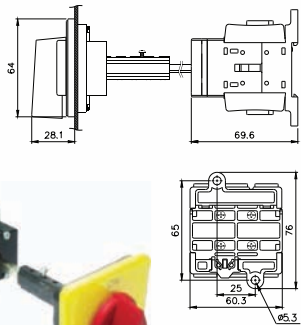

Type	Price	Type	Price
TDS40(40A)-BSB	1,830.-	TDS40(40A)-BSR	1,830.-
TDS40(40A)-BSB1	1,830.-	TDS40(40A)-BSR1	1,830.-
TDS40(40A)-BSB2	1,930.-	TDS40(40A)-BSR2	1,930.-
TDS40(40A)-BSB3	1,930.-	TDS40(40A)-BSR3	1,930.-
TDS66(66A)-BSB	2,270.-	TDS66(66A)-BSR	2,270.-
TDS66(66A)-BSB1	2,270.-	TDS66(66A)-BSR1	2,270.-
TDS66(66A)-BSB2	2,380.-	TDS66(66A)-BSR2	2,380.-
TDS66(66A)-BSB3	2,380.-	TDS66(66A)-BSR3	2,380.-
TDS80(80A)-BSB	2,960.-	TDS80(80A)-BSR	2,960.-
TDS80(80A)-BSB1	2,960.-	TDS80(80A)-BSR1	2,960.-
TDS80(80A)-BSB2	3,070.-	TDS80(80A)-BSR2	3,070.-
TDS80(80A)-BSB3	3,070.-	TDS80(80A)-BSR3	3,070.-

Detched Way Rotundity Handle

- 1 TDS40/66/80-BRB
หน้าปัดสีขาว ลูกบิดสีดำ
- 2 TDS40/66/80-BRR
หน้าปัดสีเหลือง ลูกบิดสีแดง

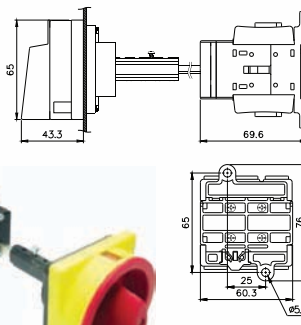

Type	Price	Type	Price
TDS40(40A)-BRB	1,830.-	TDS40(40A)-BRR	1,830.-
TDS40(40A)-BRB1	1,830.-	TDS40(40A)-BRR1	1,830.-
TDS40(40A)-BRB2	1,930.-	TDS40(40A)-BRR2	1,930.-
TDS40(40A)-BRB3	1,930.-	TDS40(40A)-BRR3	1,930.-
TDS66(66A)-BRB	2,270.-	TDS66(66A)-BRR	2,270.-
TDS66(66A)-BRB1	2,270.-	TDS66(66A)-BRR1	2,270.-
TDS66(66A)-BRB2	2,380.-	TDS66(66A)-BRR2	2,380.-
TDS66(66A)-BRB3	2,380.-	TDS66(66A)-BRR3	2,380.-
TDS80(80A)-BRB	2,960.-	TDS80(80A)-BRR	2,960.-
TDS80(80A)-BRB1	2,960.-	TDS80(80A)-BRR1	2,960.-
TDS80(80A)-BRB2	3,070.-	TDS80(80A)-BRR2	3,070.-
TDS80(80A)-BRB3	3,070.-	TDS80(80A)-BRR3	3,070.-

หมายเหตุ : ราคานี้พร้อมก้านมาตรฐาน 100 มม. มีก้านความยาวอีก 3 ขนาด สามารถเปลี่ยนได้ตามความต้องการราคาก้านยาว 150 มม. ก้านยาว 250 มม. ก้านยาว 300 มม.

tend MAIN SWITCH

เมนสวิตช์

CONTROL STATION STANDARD HANDLE

TDS-ESB

หน้าปิดสีขาว, ลูกบิดสีดำ

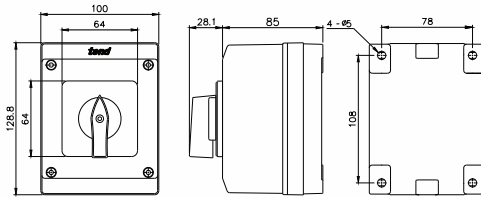

Type	Price
TDS-16ESB(16A)	1,520.-
TDS-25ESB(25A)	1,630.-
TDS-33ESB(33A)	2,050.-
TDS-40ESB(40A)	2,350.-
TDS-66ESB(66A)	2,590.-
TDS-80ESB(80A)	3,290.-

TDS-ESR

หน้าปิดสีเหลือง, ลูกบิดสีแดง

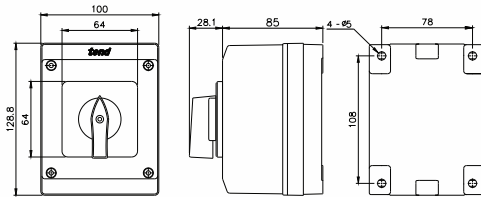

Type	Price
TDS-16ESR(16A)	1,520.-
TDS-25ESR(25A)	1,630.-
TDS-33ESR(33A)	2,050.-
TDS-40ESR(40A)	2,350.-
TDS-66ESR(66A)	2,590.-
TDS-80ESR(80A)	3,290.-

CONTROL STATION ROTUNDITY HANDLE

TDS-ERB

หน้าปิดสีขาว, ลูกบิดสีดำ

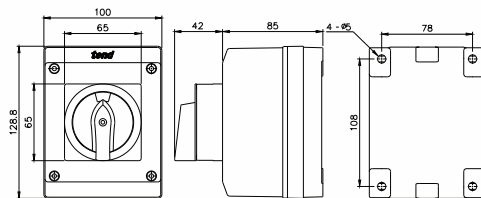

Type	Price
TDS-16ERB(16A)	1,520.-
TDS-25ERB(25A)	1,630.-
TDS-33ERB(33A)	2,050.-
TDS-40ERB(40A)	2,350.-
TDS-66ERB(66A)	2,590.-
TDS-80ERB(80A)	3,290.-

TDS-ERR

หน้าปิดสีเหลือง, ลูกบิดสีแดง

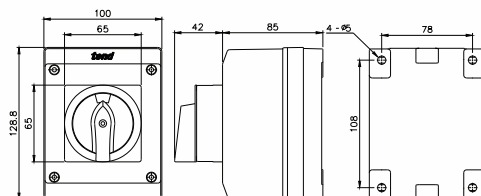

Type	Price
TDS-16ERR(16A)	1,520.-
TDS-25ERR(25A)	1,630.-
TDS-33ERR(33A)	2,050.-
TDS-40ERR(40A)	2,350.-
TDS-66ERR(66A)	2,590.-
TDS-80ERR(80A)	3,290.-

tend MAIN SWITCH

เมนสวิตช์

CONTROL STATIONS

TDS4-ESB



TDS4-ESR

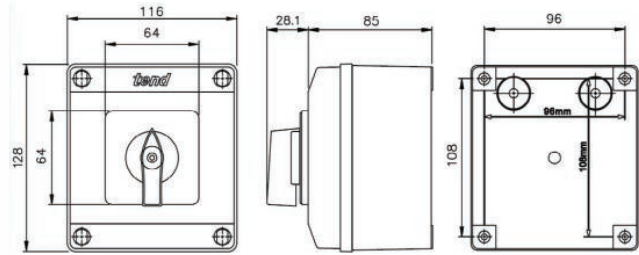

TDS4-ERB



TDS4-ERR

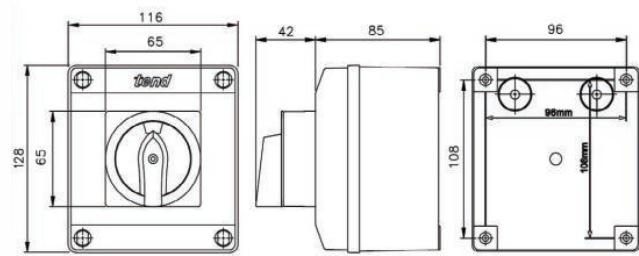

REINFORCING CONTACT BLOCK & COVER

TDS16/33-AF/AB □ □ :blank=1P, 2=2P (Single side)



Designation	Description
TDS16-AF	16A Fixed reinforcing contact block
TDS33-AF	33A Fixed reinforcing contact block
TDS16-AB	16A Detachable reinforcing contact block
TDS33-AB	33A Detachable reinforcing contact block

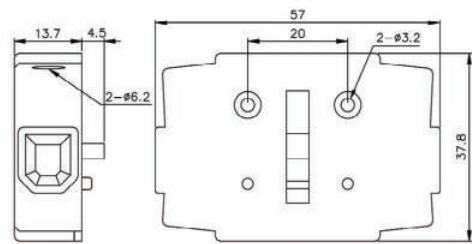

1NO

- Can be used as the main contact block with the same voltage, or as an reinforcing contact block with different voltage.
- A maximum of two sets of reinforcing contact blocks can be attached on one side.

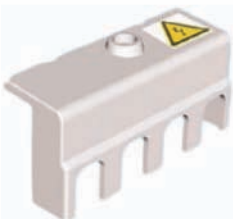

Designation	Description
TDS40-C4	40A-4P cover (16A~40A)
TDS80-C4	80A-4P cover (66A~80A)